



TECHNICAL DATA SHEET

Crown Battery Mfg. Co. • Fremont, Ohio USA
419-334-7181 • FAX 419-334-7124

31DC36

Commercial Deep Cycle Battery

Crown Battery Manufacturing Company offers a complete lineup of high-performing and low-maintenance commercial deep cycle batteries produced in standard BCI industry profiles for voltage, electrical capacity and physical dimension. Crown Battery's innovative and proven deep cycle product design makes it the battery of choice for many tough commercial battery applications, including commercial floor care and aerial access equipment, electric motorcars, personnel carriers, material handling equipment and photovoltaic systems.



Available Terminal

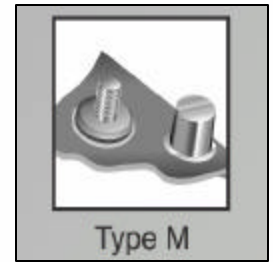

SPECIFICATIONS

Nominal Voltage		12 Volts	
Amp Hour Capacity		140 (C20)	110 (C5)
Reserve Capacity Minutes		200 @ 25 Amperes	
Physical Characteristics	Length	13.13"	334 mm
	Width	6.88"	175 mm
	Height	9.38"	238 mm
	Wet Weight	67 Lbs	30.4 Kgs
Terminal Options		BCI Type M	

ELECTRICAL SPECIFICATIONS

Amp Hour Capacity	20 Hour Rate	7.00 A	140 Ah
	10 Hour Rate	12.50 A	125 Ah
	5 Hour Rate	22.00 A	110 Ah
	2 Hour Rate	41.00 A	82 Ah
Internal Resistance	80 F	27 C	8.7 mOhm
Capacity affected by Temperature (20 Ah Rate)	104 F	40 C	102%
	80 F	27 C	100%
	32 F	0 C	65%

Cover Style:	Exposed Vent Opening With PROeye Monitor
Cover Vent Style:	Raised Pod Vent
Container and Cover Material:	Black Polypropylene
Case to Cover Seal Method:	Heat Seal
Inner-Cell Connector Type:	Through Partition Weld
Plate Lug to Collector Bar Fusion Method:	Inverted Automatic Cast-On
Number of Plates per Battery:	114 Plates
Positive Grid Material:	Antimony Lead Alloy
Positive Grid Design:	Z ³ CL Diagonal
Positive Plate Dimension:	5.625" x 5.000" x 0.070" 143mm x 127mm x 1.8mm
Negative Grid Material:	Antimony Lead Alloy
Negative Grid Design:	Z ³ CL Diagonal
Negative Plate Dimension:	5.625" x 5.000" x 0.055" 143mm x 127mm x 1.4mm
Separator Type:	Microporous Polyethylene Envelope with Glass

Visit our website at
www.crownbattery.com

Crown Battery Manufacturing's team of research and development engineers welcome the opportunity to discuss your technical requirements during the design and specification stage. To access this technical assistance, please contact Crown Battery Manufacturing's Customer Service Department at 800.487.2879 / sales@crownbattery.com / FAX 419.334.7124.

Recommended Charge Profile:

Following discharge, constant current charge the 31DC36 battery at 15 to 20 amperes until the battery voltage measures 2.42 volts per cell (14.52 volts open circuit voltage).

The constant voltage charge phase begins after the gassing point (2.42 VPC) is achieved. During the constant voltage phase, the charger voltage limit is regulated to the gassing point of 2.42 volts per cell, while the input current is allowed to gradually fall off. When the input current drops to the finish rate setting of 4 amperes, the charging phase will change from constant voltage to a sustained 4 ampere constant current mode. The charging cycle will be terminated 3.5 to 5 hours from the gassing point, with factors such as ambient temperature, battery condition and depth of discharge affecting the charge completion time.

The 31DC36 battery should receive a full recharge following the completion of each discharge, along with a weekly equalization service charge. During the equalization charge cycle the finish rate charge time is extended by 3 hours (6.5 to 8 hours from the gassing point).

The charge factor of the standard recharge should be equal to or greater than 1.07 (107%). The charge factor of the equalizing cycle should be equal to or greater than 1.15 (115%).

Please contact Crown Battery Manufacturing Company's engineering department with any questions regarding this charge profile specification.

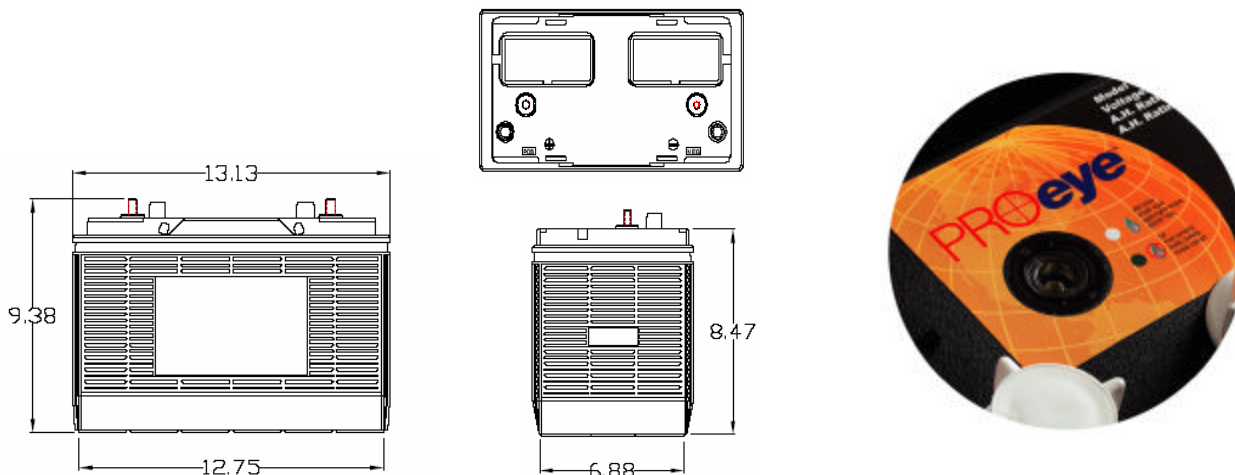

The Power Behind Performance

Data are nominal and should not be construed as maximum or minimum values for specification or for final design. Data for this product type may vary from that shown herein.