



TECHNICAL DATA SHEET

Crown Battery Mfg. Co. • Fremont, Ohio USA
419-334-7181 • FAX 419-334-7124

CR-350 Commercial Deep Cycle Battery

Crown Battery Manufacturing Company offers a complete lineup of high-performing and low-maintenance commercial deep cycle batteries produced in standard BCI industry profiles for voltage, electrical capacity and physical dimension. Crown Battery's innovative and proven deep cycle product design makes it the battery of choice for many tough commercial battery applications, including commercial floor care and aerial access equipment, electric motorcars, personnel carriers, material handling equipment and photovoltaic systems.



Available
Terminals

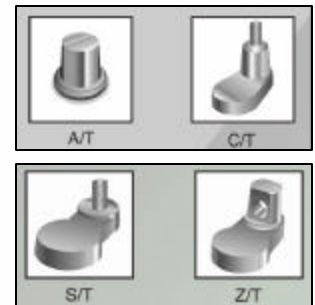

SPECIFICATIONS

Nominal Voltage	6 Volts		
Amp Hour Capacity	350 (C20)	285 (C5)	
Reserve Capacity Minutes	210 @ 75 Amperes		
Physical Characteristics	Length	12.19"	310 mm
	Width	7.19"	183 mm
	Height	16.50"	419 mm
	Wet Weight	113 Lbs	51.4 Kgs
Terminal Options	A/T, C/T, S/T, Z/T		

ELECTRICAL SPECIFICATIONS

Amp Hour Capacity	20 Hour Rate	17.50 A	350 Ah
	10 Hour Rate	31.30 A	313 Ah
	5 Hour Rate	57.00 A	285 Ah
	2 Hour Rate	102.0 A	204 Ah
Internal Resistance	80 F	27 C	7.2 mOhm
Capacity affected by Temperature (20 Ah Rate)	104 F	40 C	102%
	80 F	27 C	100%
	32 F	0 C	65%

<i>Cover Style:</i>	Exposed Vent Opening
<i>Cover Vent Style:</i>	Quarter-Turn Bayonet Style
<i>Container and Cover Material:</i>	Black Polypropylene
<i>Case to Cover Seal Method:</i>	Heat Seal
<i>Inner-Cell Connector Type:</i>	Through Partition Weld
<i>Plate Lug to Collector Bar Fusion Method:</i>	Inverted Automatic Cast-On
<i>Number of Plates per Battery:</i>	45 Plates
<i>Positive Grid Material:</i>	Antimony Lead Alloy
<i>Positive Grid Design:</i>	Z ³ Horizontal Pellet
<i>Positive Plate Dimension:</i>	5.750" x 11.500" x 0.140" 146mm x 292mm x 3.6mm
<i>Negative Grid Material:</i>	Antimony Lead Alloy
<i>Negative Grid Design:</i>	Z ³ Horizontal Pellet
<i>Negative Plate Dimension:</i>	5.750" x 11.500" x 0.105" 146mm x 292mm x 2.7mm
<i>Separator Type:</i>	Microporous Polyethylene Envelope with Glass

Visit our website at
www.crownbattery.com

Crown Battery Manufacturing's team of research and development engineers welcome the opportunity to discuss your technical requirements during the design and specification stage. To access this technical assistance, please contact Crown Battery Manufacturing's Customer Service Department at 800.487.2879 / sales@crownbattery.com / FAX 419.334.7124.

Recommended Charge Profile

Following discharge, constant current charge the CR-350 battery at 42 amperes until the battery voltage measures 2.42 volts per cell (7.26 volts open circuit voltage).

The constant voltage charge phase begins after the gassing point (2.42 VPC) is achieved. During the constant voltage phase, the charger voltage limit is regulated to the gassing point of 2.42 volts per cell, while the input current is allowed to gradually fall off. When the input current drops to the finish rate setting of 13 amperes, the charging phase will change from constant voltage to a sustained 13 ampere constant current mode. The charging cycle will be terminated 3.5 to 5 hours from the gassing point, with factors such as ambient temperature, battery condition and depth of discharge affecting the charge completion time.

The CR-350 battery should receive a full recharge following the completion of each discharge, along with a weekly equalization service charge. During the equalization charge cycle the finish rate charge time is extended by 3 hours (6.5 to 8 hours from the gassing point).

The charge factor of the standard recharge should be equal to or greater than 1.07 (107%). The charge factor of the equalizing cycle should be equal to or greater than 1.15 (115%).

Please contact Crown Battery Manufacturing Company's engineering department with any questions regarding this charge profile specification.

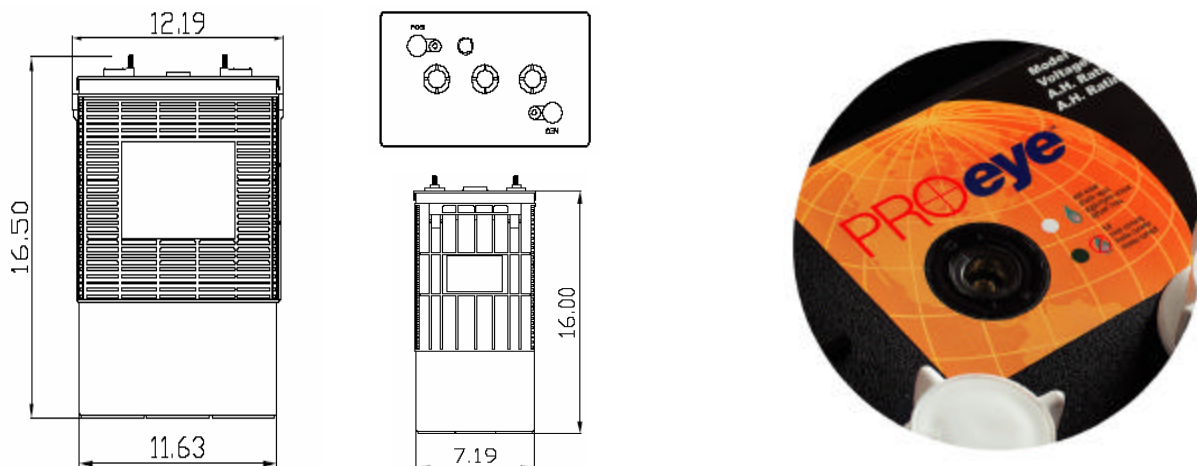

The Power Behind Performance

Data are nominal and should not be construed as maximum or minimum values for specification or for final design. Data for this product type may vary from that shown herein.