

Operation and Installation Manual

PICCOLO

High Performance Sinewave Inverter

Model: SEAP-12-150 & SEAP-24-250



Solar Energy Australia Pty Ltd ACN 081 639 038

Sydney: 4 Beaumont Road, Mt Kuring Gai NSW 2080
Tel: (02) 9457 2277 Fax: (02) 9457 2255

Melbourne: 1/15 Nicole Close, North Bayswater, VIC 3153
Tel: (03) 9761 5877 Fax: (03) 9761 7789

Email: sales@solaraustralia.com.au Web site www.solaraustralia.com.au

CONTENTS

PAGE 2	CONTENTS
PAGE 3	INTRODUCTION
PAGE 4	WARRANTY
PAGE 6	QUICK START GUIDE / WARNING
PAGE 7	INSTALLATION / BATTERY WIRING
PAGE 8	PRE-INSTALLATION INFORMATION
PAGE 9	ELECTRICAL REQUIREMENTS / INSTALLATION
PAGE 10	AC WIRING
PAGE 11	DC WIRING VEHICLE
PAGE 12	START-UP PROCEDURE / FAULT FINDING
PAGE 14	HOW LONG WILL MY BATTERY LAST?
PAGE 15	TECHNICAL SPECIFICATIONS



INTRODUCTION

Thank you for choosing to purchase another quality inverter from Solar Energy Australia. This product has been developed to provide you with years of trouble free operation. Your SEA inverter provides True Sinewave output with power quality and voltage regulation equal to or better than grid electricity.

It is important to us that you get the best out of your inverter, so please take a few minutes to read this manual carefully, it could save you from frustration. If you have any comments regarding our products or service, please do not hesitate to contact us to discuss your thoughts.

Remember: As soon as your Solar Energy Australia inverter has been installed please complete and return your warranty card. This will enable us to efficiently handle any service enquiries you may have, and keep you updated with any relevant important updates.

Features Include

- True Sinewave Output
- Low Total Harmonic distortion
- Excellent high surge capability
- Extremely high overall efficiency
- Intelligent overload control
- Short circuit protection
- Dynamic battery low voltage control
- Designed for harsh climatic conditions
- Aluminium base with steel cover



WARRANTY TERMS & CONDITIONS

Solar Energy Australia warrants this inverter against defects in material or workmanship, for a period of two (2) years from the date of purchase, when in normal use and service. The warranty period will provide a total of two (2) years if a completed warranty card is received within 60 days of purchase. No warranty will be provided on units which have not been paid for in full.

This warranty does not extend to products which have been opened, altered or repaired by persons other than those authorised by Solar Energy Australia or to products which become defective due to acts of God, fire, sabotage, vandalism, contaminated fluids, negligence or failure to operate, house and maintain the product in accordance with instructions provided in this manual. **It is extremely important that all installation instructions contained within this manual are strictly adhered to. Failure to do so will void your warranty.** Except for the foregoing expressed warranty, Solar Energy Australia makes no other warranty, expressed or implied, including but not limited to, the warranty of merchantability or fitness for a particular purpose.

Solar Energy Australia will repair or replace the defective product in accordance with its best judgement. For service under warranty, the buyer must contact Solar Energy Australia to obtain a “Return Materials Advise” (RMA) document and shipping instructions before returning the unit. Products returned without prior authorisation may be delayed. The buyer will pay all charges incurred in returning the product to the factory, including any charges incurred for the uninstallation or reinstallation of the inverter and / or its system components. Solar Energy Australia will pay return freight charges, if the product is found to be defective, within the terms of this warranty. Repair or replacement of any unit does not extend the original warranty terms in any way.



WARRANTY TERMS & CONDITIONS (CONT.)

This warranty does not cover repairs made necessary due to the product coming in contact with dirt, abrasives, moisture, erosion, corrosion, varnish or other similar, or failure due to poor quality or poor condition of batteries or other system components.

Solar Energy Australia reserve the right, with some models, to supply an accredited installer with replacement parts (Aust. only). This may allow the unit to become operable much quicker. This choice is at Solar Energy Australia's discretion. Solar Energy Australia will in no way be held responsible for any losses incurred due to the malfunctioning or failure of a product.

Suitably qualified personnel must carry out wiring. Failure to do so will void warranty.

If you have any questions about this warranty please do not hesitate to contact us.



QUICK START GUIDE

The following guide is designed to get you up and running as quickly as possible.

1. Unpack your "Piccolo" inverter, ensure there has been no damage during transport. If so, report this to your supplier immediately.
2. Connect your "Piccolo" to an appropriate 12 or 24 volt battery.
3. A small spark may be seen when connecting to the battery, this is normal.
4. If all is well, the small LED on the rear of the inverter will be green.
5. Plug your appliance into the front power point of the "Piccolo".
6. Switch on appliance.
7. You're on your way.

WARNING

Voltages of up to 1000V can be present inside your "Piccolo"; under no circumstances should you attempt to open this unit. Opening this unit will also void any warranty claims.

The output voltage from your "Piccolo" is basically the same as the power outlets in your home, office or factory. Despite this voltage being generated from a battery, it is just as dangerous as mains electricity. The wiring into and out of your "Piccolo" MUST be in a safe condition.

Do Not Allow any AC voltage from another source such as a generator or mains electricity to come in contact with your "Piccolo", this will result in permanent damage and will void your warranty.

Always ensure your "Piccolo" is connected to the correct battery voltage.

INSTALLATION

The following must be adhered to when installing your "Piccolo" to ensure safety and reliability;

- Choose a dry dust free position for your "Piccolo".
- This unit is not intended for outdoor use or under a vehicle.
- Easy access for children must be avoided.
- Allow a minimum of 10cm clearance around the inverter for ventilation.
- Your "Piccolo" can be installed at any angle.
- Keep your "Piccolo" as far away as possible from radio transmitters or receivers.
- Use small angle brackets into the spare holes provided to securely mount your inverter.

BATTERY WIRING

For constant loads of up to 100watts your 12volt "Piccolo" can be used directly from the lighter socket of your vehicle, this should be fused through your vehicles wiring system. DO NOT INCREASE THE CURRENT RATING OF THIS FUSE.

For constant loads in excess of 100watts such as computers, you should remove the lighter socket and replace with a heavy duty polarised DC plug, or wire directly through a fuse or circuit breaker to the battery (consult your supplier or a qualified installer for further information). See electrical specifications for maximum current draw.

Important. Extreme care must be taken to ensure correct polarity is connected to your inverter, reverse connection will cause damage to the inverter and is NOT covered under warranty.

PRE INSTALLATION INFORMATION

Batteries

Before installing your Sine Wave Inverter, it is important that you have appropriately sized batteries. A battery that is too small will not allow the inverter to perform to its full specification. Battery performance will vary between different styles of batteries. For example, a Deep Cycle battery will tolerate deep discharges on a regular basis much better than a cranking battery, whereas a cranking battery may provide higher voltage when high battery current is being drawn (eg, when your inverter is starting a motor or Television).

Model	Recommended Minimum Battery Capacity	Maximum Current Draw of Inverter	Recommended Battery Fuse
SEAP-12-150 SEAP-24-250	50Ah 75Ah	40Amps DC 34Amps DC	40 Amp 30 Amp

Battery Terminology

I = Current.

This is the measure of electrical power flowing. This is expressed in Amps. For example, **I = 6A** means 6 Amps.

Ah = Ampere Hours.

This is the amount of energy a battery can store. In theory this means that a 200 Ah battery could supply 1 Amp for 200 hours.

CCA = Cold Cranking Amps.

This is the maximum amount of current that the battery can supply for a short period of time.

NOTE: Batteries joined in series (+ to -) will increase the voltage but not the Ah. Batteries joined in parallel (+ to +, - to -) will increase the Ah but not the voltage.

For example: 2 x 12V / 200 Ah batteries joined in series = 24V / 200Ah

2 x 12V / 200 Ah batteries joined in parallel = 12V / 400 Ah

There should be no more than 2 batteries in parallel

ELECTRICAL REQUIREMENTS

We refer you to Australian Standard AS4509 for further information regarding home power installations.

- DC Input voltage of the inverter must be the same as the battery bank voltage. Please see specification for your model .
- DC cabling must be connected to the correct polarity terminal of the battery bank (Red = Positive, Black = Negative).
- It is not recommended that the DC cables to the inverter be extended. If this is necessary then you will have to increase the DC cable size. Consult your supplier/installer for this calculation.
- Do Not Connect 240V AC or any other power source to the 240V output of the inverter as this will cause irreparable damage to the inverter.
- If you need to switch from Inverter to Generator or Shore Power it is absolutely critical that you install a double-pole Break before Make changeover switch, switching both active and neutral between the inverter and the incoming AC supply.

INSTALLATION

Warning: Please read these instructions thoroughly before commencing installation. Installation should be performed by a competent professional electrical / renewable energy installer, as dangerous voltage can be present. **All relevant Australian Standards must be strictly followed. A licensed Electrician must carry out all AC wiring.**

The following steps should be completed in the order shown in this section.

Unpacking & Mounting

- a) Unpack your inverter from its shipping container and inspect the unit for any obvious transit damage. Report any concerns immediately to your supplier. Please keep original packaging in case it is required for re-transport at a later date

- b) Mount the inverter to a suitable surface, paying close attention to the mounting requirements set out below.
- Select a site that is dry and free of salt or moisture-laden air, dust, exhaust or battery gases and access to any rodents. The unit can be mounted vertically or horizontally.
 - **Never** mount the inverter directly above the batteries.
 - Mount the inverter as close to the batteries as possible, but no closer than 500mm, mounting should be on a solid surface capable of withstanding temperatures of 60° C.
 - Allow a cooling space of at least 200mm all around the inverter. Placing the inverter in a cupboard or small enclosure may reduce the available output power. The installation site should not be susceptible to temperatures in excess of 50° C.

AC WIRING

Important: All AC wiring must comply with relevant Australian and local standards, and be performed by a licensed electrician to satisfy warranty requirements and conditions.

Connect active, neutral and earth to a 10 amp 3 pin male AC plug top. Due to the use of a large transformer, max galvanic isolation is provided between the input and output. This means that your inverter is compatible with M.E.N installations.

Tips

- Avoid running AC/DC wiring next to other DC wires.
- Avoid running AC/DC wiring near any antenna wiring.
- Avoid running AC/DC wiring near audio equipment.

DC WIRING—VEHICLE

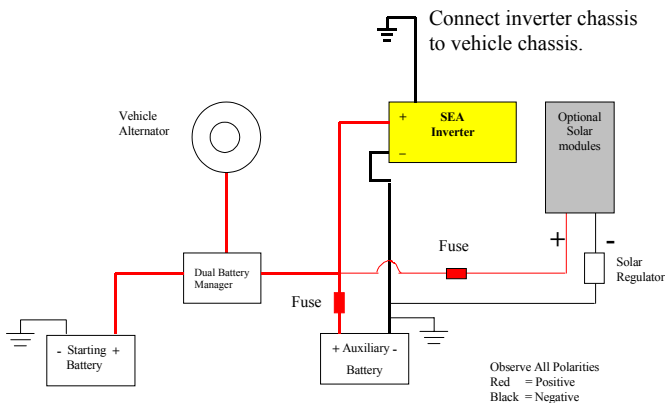

The primary consideration is to ensure that the battery bank voltage matches the DC input voltage rating of the inverter. The batteries should be located only a short distance from the inverter in order to obtain best results, but not closer than 500mm. A battery fuse must be installed no closer than 500mm from the battery to protect all wiring connected to the battery, we suggest the use of a 40 Amp fuse..

Before making any connections, ensure there is no load connected to the inverter. Connect the inverter DC input cables to the battery terminals via the battery fuse, ensuring the correct polarity (**RED** = positive).

START-UP PROCEDURE

Once all DC and AC wiring has been completed and checked you are now ready to start your "Piccolo".

Make sure no AC loads are switched on.

Apply DC power to the input leads, the LED at the rear of the "Piccolo" will light green. AC voltage is now present at the outlet, connect the AC wiring.

Should the LED at the rear flash RED then the "Piccolo" has shut-down for any of a number of reasons. See the fault finding section for assistance.

FAULT FINDING

Your "Piccolo" inverter is protected against a number of faults. Each time a fault occurs the inverter automatically tries to restart every 20 seconds, or when the cause of shutdown has been removed. The time before the unit actually starts again can vary from a few seconds to a few hours.

Always disconnect the DC supply before attempting to fault find.

1. Check the battery voltage is within tolerance, voltage maybe lost on its way to the inverter. Make sure all connections are clean and tight. Ensure cable is of an appropriate size, thin cable can drop voltage, the longer the cable the heavier duty it should be. (Check with your installer or supplier).

The input voltage may be too high, check for correct operation of any battery charges or Solar modules etc.

2. Check the rating label of your appliance against the specifications of your "Piccolo". If the appliance is too large for the inverter, the "Piccolo" will shut down.

FAULT FINDING (CONT.)

Some appliances such as televisions and motors require an initial extra start up or surge power. To allow for the start up power of a motor, take the continuous rating of the motor and multiply this by a figure of six. This figure should not exceed the surge power of your "Piccolo".

e.g. Motor = 40watts, multiply $\times 6 = 240$ watts, this is within the surge rating of your "Piccolo". This surge power usually only lasts a couple of seconds and normally occurs when the appliance is first turned on.

3. Inverter shuts down due to Over Temperature

Your inverter will safely provide the output power as described in the technical data section in the conditions specified. If your inverter shuts down and indicates over temperature, it may be that you have exceeded one of the parameters.

Check for the following:

- Ensure the inverter has adequate ventilation, insufficient ventilation can severely restrict the power output of your inverter.
- Ensure the true power rating of your appliance (including power factor) does not exceed the rating of your inverter.

4. Inverter shuts down when trying to start a load.

When starting a load such as a motor it may cause the inverter to shut down, if this is the case

- Ensure the battery voltage is within spec when the appliance is trying to start, if not, you may need to increase the size of your batteries.
- If battery voltage is OK then the inverter may be too small, consult your Solar Energy Australia representative

5. Screeching noise on radio when inverter is operating.

Your Solar Energy Australia inverter is manufactured to the highest standards for the reduction of EMI(Electro Magnetic Interference). It is still possible however that in extreme cases, interference may be noticeable in radio's or Television sets. Below are some suggestions to try to reduce this noise.

FAULT FINDING (CONT.)

- If possible run a heavy gauge earth wire from battery negative to a moist ground stake, also connect this to the earth stud on the chassis of the inverter.
- Separate AC and DC wiring.
- Improve signal strength of receiver by improving antenna.
- Reposition inverter as far away from receiver as possible.

6. Inverter stays shut down for a long time after overload.

The inverter is responding to either a severe overload or repeated overloads turn the inverter's circuit breaker OFF for 30 seconds and then reconnect. If the cause of the original shutdown is still present, the inverter will shut down again. Reduce load or allow inverter to cool down.

HOW LONG WILL MY BATTERY LAST?

The state of charge of your battery is critical to the performance of your inverter. Follow this guide to calculate how long your battery will last.

Step 1 Take the power rating of your appliance and divide this by 10. This is the approximate current the inverter will draw from your battery. (Divide by 20 for 24V; 40 for 48V).

Step 2 Take the Ah (Ampere Hour) rating of your battery and divide it by two. This is the conservative amount of useable power in your battery.

Step 3 Now divide the current draw into the useable battery capacity. This is the maximum number of hours you should use this appliance. This equation presumes that no other charging has taken place.

Example: A 67 watt TV running on a 100 Ah 12V battery

Current draw = $67 / 10 = 6.7$ Amps DC

Useable battery capacity = $100 / 2 = 50$ Ah

Time = $50 / 6.7 = 7.4$ hours

TECHNICAL SPECIFICATIONS

	SEAP-12-150	SEAP-24-250
DC Input Voltage (Battery Voltage)	12volt	24volt
DC Input Voltage Range	10.5-16 V DC	21-32 V DC
Continuous Output Power @ 30°C	150watt	250watt
Max Continuous DC Current	16Amp DC	13Amp DC
Continuous AC Output Current	.66A AC	1.10A AC
Short Term Output Current	42A DC	34A DC
Output Voltage	225v AC +/-2%	
Output Frequency	50Hz +/-0.5%	
Output Wave Shape	True Sine Wave	
DC Battery Draw No Load	170mA	100mA
Power Factor Limitations	Nil	
Peak Efficiency	90%	92%
Total Harmonic Distortion	< 4%	
AC Outlet	3 pin socket	
Input/Output Isolation	1875V AC RMS	
Battery Lead Length	1 meter	
Dimensions (W x H x L) mm	110 x 75 x 190	
Weight	1.8 kg	2.5 kg
Chassis	Aluminium base with chromate conversion, steel powder coated lid	
Warranty	2 years upon completion and return of warranty card	

- All specifications are at unity power factor & 25°C unless otherwise stated.
- Through a policy of continued development, Solar Energy Australia reserves the right to specification changes without notice.